

Wilkhahn

Timetable Lift. 615 range.





Timetable Lift.

Timetable Lift taps into new opportunities for innovation spaces and huddle rooms. These tables aren't just mobile, combinable and nest compactly into one another, but also add flexibility in terms of height. Electrically adjustable in height from 73 cm to 139 cm, they're perfect for hot desking where people both sit and stand and an excellent choice for scalable seminar and project spaces where different postures are often adopted and for spacious multipurpose meeting and presentation spaces.

The superbly designed tables are compact to stow away, wheel in as required, easy to set up in one step and set to the right height at the touch of a button. Optional battery operation enables mobility regardless of where the power supply's located. And what's more, if surfaces with dry-wipe laminate are chosen, the table also turns into a mobile, flip-top projection screen and whiteboard.



Timetable Lift. 615 range. Technical details.

Wilkhahn

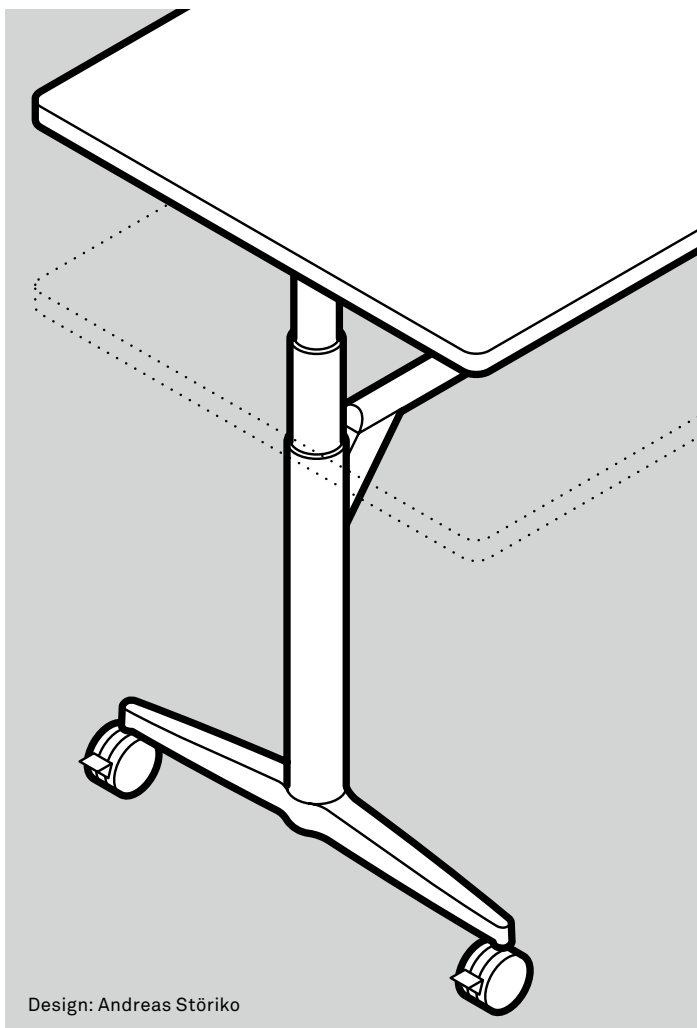

Design: Andreas Störiko

Function

A mobile table range with flip-top table tops.

The Timetable range is ideal when combined with the Confair and Logon table ranges for multi-functional use of high-quality training, conference, presentation and meeting rooms.

With a flip-top table top, Timetable tables nest compactly into one another. Timetable Lift come with a locking mechanism and staggered storage is possible.

Timetable Lift is electrically height-adjustable (73-139 cm), optionally battery operated. With a surface that can be written and that's optionally magnetic for use as a whiteboard and projection screen.

Frame

Aluminium foot section, bright chrome-plated, polished or with a silver satin finish or black coating. Electric telescopic column with an integrated sensor (to stop things getting stuck in it). Uprights and crossways underframe in tubular steel, coated in black or with a silver satin finish. Table top bearer in steel profile, draw rod in round steel tubing, coated black. Lockable, height adjustable, swivel castors with a black polyamide tyre are the standard version for carpeted floors; castors available with a polyurethane tyre for hard floors (please specify when ordering). The electrical

control, including a three-metre supply lead and cable mesh, as well as the fitting for the optional battery are mounted underneath the table top.

Core material of table top

Particle board with bullnose or straight wood lipping with integral, impact-resilient profile in black elastomer or straight plastic lipping. Timetable Lift has an integrated button to adjust the height.

Table top group 1 – laminate

Table top thickness 26 mm

Type 1

Laminate (single colour) based on Wilkhahn's colour and surface samples with wood lipping, natural oiled finish. Wood decor laminate from the Wilkhahn colour and surface samples with colour matched plastic lipping.

Type 2

Soft matt laminate from the Wilkhahn colour and surface samples with wood lipping in natural oiled finish or colour matched with the plastic lipping. Anti-reflective, soft-touch surface with anti-fingerprint characteristics.

Table top group 2 – veneer

Table top thickness 26 mm

Type 1

Beech veneer according to Wilkhahn woodstain colour samples with laminated beech lipping, or oak or ash veneer according to Wilkhahn woodstain colour samples with lipping, mostly colour matched with the veneer.

Type 2

Maple, elm or walnut veneer from the Wilkhahn woodstain colour samples with lipping colour matched as far as possible with the veneer.

Veneer types

As a standard, the veneer panels are slip-matched. Surfaces sealed with clear lacquer:
open-pore: Oak, ash, walnut and elm veneer
closed-pore: maple and beech veneer.
Some specific growth features possible.

Table top with board capability

Table top thickness 26 mm
White laminate with colour matched plastic lipping. Table top can be written on with board marker pens, can be dry wiped and used as a projection screen, optionally magnetic.
Further finishes for the formats shown in the price list are available on request.

Battery box

Compact and powerful lithium ion battery with 2.2 AH allowing the table to be raised about 40 times after being fully charged. With and LED charge indicator and acoustic signal to indicate recharging is required. With re-charger that can be retrofitted.

Edge profiles



Standard version: Bullnose double with integral, impact-resilient profile

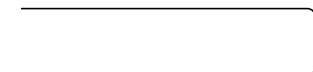

Alternatively: Straight with integral, impact-resilient profile



Straight plastic edging

Standards

The height-adjustable tables comply with the DIN 147 technical report and DIN EN 527, as well as the GS requirements.

When placing repeat orders, please indicate whether your table tops have slip-matched or book-matched veneer.

Subject to change.

Timetable Lift. 615 range. Product versions.

Wilkhahn

Table top groups



Laminate, soft matt laminate, veneer type 1 or 2, you can find further surfaces in our media center.

Laminate. The material is made by bonding cellulose and décor paper layers, as well as resin, by applying heat and pressure. This produces an extremely tough surface that comes in a variety of different colours. Laminate is highly recommended for areas where the tables are subject to a lot of wear and tear because they are frequently moved around for example.

Wood veneers. Natural wood is a living material: in the way it looks and changes over the years. Sometimes more significantly and sometimes more subtly, depending on the type of wood and how light it is. If a more consistent look is preferred, stained surfaces or industrially produced veneer (e.g. mocha) are available.

Foot section and upright



Bright chrome-plated or polished aluminium, coated in black or with a silver satin finish

Timetable Lift. 615 range. Edge shapes.

Wilkhahn

Edge profiles



Standard type: bullnose with integrated impact-resilient profile

Alternatively: straight with integrated impact-resilient profile

Straight plastic edge

Bullnose edge with a black impact-resilient profile, table top 26 mm thick



Bullnose edge with a white impact-resilient profile, table top 26 mm thick



Coated bullnose edge with a black impact-resilient profile, table top 26 mm thick



Straight edge with a black impact-resilient profile, table top 26 mm thick



Straight edge with a white impact-resilient profile, table top 26 mm thick



Straight plastic edge, table top 25 mm thick



Timetable Lift. 615 range. Accessories and other items.

Wilkhahn



An integrated control unit and optional battery allow mobile and precision adjustment at the touch of a button: from standard table height to in-between heights for dynamic stools and sitting-standing items of furniture to the height of a projection screen and whiteboard.

Timetable Lift. 615 range. Models and dimensions / example configurations.

Wilkhahn

615/00

Electrically height adjustable (73 - 139 cm)
Polished aluminium foot section, aluminium-coated uprights and underframes

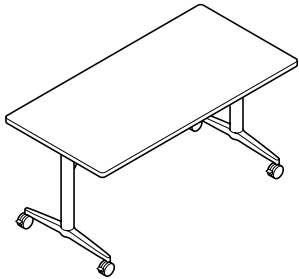

615/10

with board capability
electrically height-adjustable (73 - 139 cm)
white table top, can be written on with board marker pens, can be used as a projection screen
Polished aluminium foot section, aluminium-coated uprights and underframes

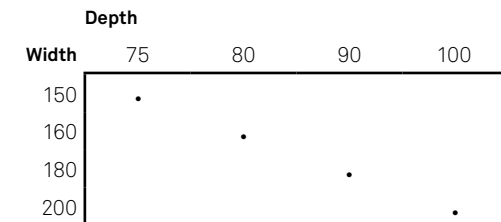
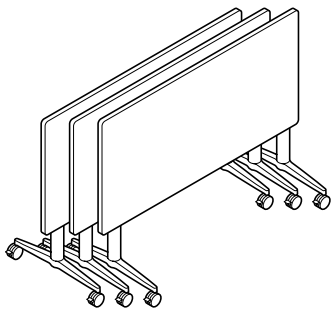
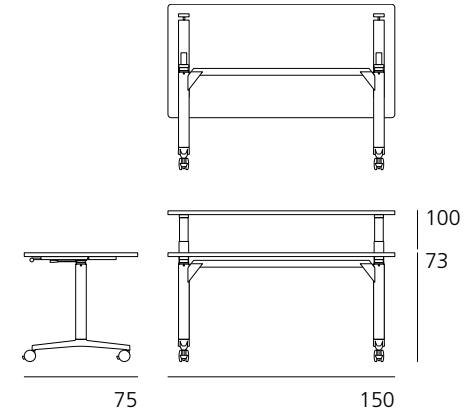
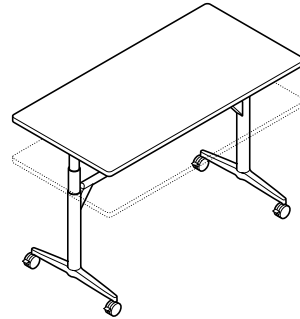

• Available

Timetable Lift. 615 range. Awards / standards / certificates.

Wilkhahn

Product certificates / product standards

The height-adjustable tables comply with the DIN 147 technical report and DIN EN 527, as well as the GS requirements.

Company's certificates, memberships



Mitglied der
DGNB
Deutsche Gesellschaft für Nachhaltiges Bauen
German Sustainable Building Council

